

## Study Analysis of Cascaded IPFC using Hysteresis Controller

Sridhar Babu Gurijala<sup>1</sup>. Dwarakesh S<sup>2</sup>. Rajesh Kunchala<sup>2</sup>. Sai Krishna Yadav Nagan<sup>2</sup>.  
Sai Vardhan Jella<sup>2</sup>. Rohith Reddy Godala<sup>3</sup>

<sup>1</sup>Associate Professor, Department of EEE, St. Martins Engineering college, Secunderabad, Telangana, India. sridharbabu16@gmail.com

<sup>2</sup>Student, Department of EEE, St. Martins Engineering college, Secunderabad, Telangana, India

<sup>3</sup>Student, Faculty of Power and Electrical Engineering, IEEI, Riga Technical University, Riga, Latvia

### ABSTRACT

Interline power flow controller is series compensation FACTS device. Which helps in transfer of power among multiple lines. Control system in IPFC plays a key role in power transfer among these lines. IPFC is the back to back connection of voltage source converters connected back to back with a common DC link. Voltage source converter is the multilevel inverter. Multilevel inverter helps in generating a sinusoidal output with DC input, Here we have used cascaded multilevel inverter and controlled using hysteresis controller.

**Keywords:** Flexible AC transmission systems, Interline power flow controller, Cascaded multilevel inverter, hysteresis controller.

### 1. INTRODUCTION

Industrialization and modernization has increased a huge demand to electricity. Heavy electric equipment and industries which require the supply of pure supply to the loads, But most of them being nonlinear, many issues arises. Environmental hazards are putting a huge stress on the lines which are resulting in power quality issues. In order to solve these problems Flexible AC transmission devices have come into picture. FACTS devices help in solving many power quality issues. Inverter is one of the key components of FACTS devices. Multilevel inverter helps in transmission and transfer of power among the lines. With the implementation of IPFC among the lines, It compensated the over loaded and under loaded lines and helps in mitigating the harmonics.

### 2. CASCADED MULTI LEVEL INVERTER

It is a power electronic device. This inverter gives multiple voltage levels at the output, and it converts DC power to AC power at desired voltage and frequency. These are used in many industrial applications. These are used for medium voltage and high power applications. This inverter generates the desired output voltage from several DC power input levels. These are of two types

1. Diode clamped multilevel inverter
2. Flying capacitors multilevel inverter
3. Cascaded H-bridge multilevel inverter

The diode clamped multilevel inverter uses diodes to provide multiple voltage levels to the capacitor banks. The flying capacitor multilevel inverter uses capacitor. It is a series connection of capacitor clamped cells. The cascaded H-bridge multilevel inverter uses capacitors and switches and it requires the less number of components in each level [2]. Multilevel inverter reduces the harmonic distortion. And it operates in both switching frequencies like in higher switching frequency and lower switching

frequency. Cascaded inverter topology of inverter uses less number of switches when compared to other and soft switching is probable by fresh switching methods. In a cascaded h bridge inverter while L number of bridges are cascaded in a phase then the number of amount produced voltage levels is given by  $2L+1$  and voltage step of each level is given by  $V_s/2L$ . The switching mechanism for cascaded 5 level inverter transmission system regularization with 5-level cascaded ipfc. cascade h bridge each inverter level can generate five different voltage outputs,  $+2v_s, +v_s, 0$  and  $-v_s, -2v_s$  by connecting the direct current source to the alternating current output by different combinations of the four switches. Switches  $s_1, s_2, s_3, s_4, s_5, s_6, s_7,$  and  $s_8$  are switched in different modes of switching sequences to generate output voltages across output terminals of the h bridge module explain the possible switching state to generate a 5-level output voltage [6]. The major applications of this inverter involve motor drives, electric vehicle drives, active filters, power factor compensators, interfacing with renewable energy sources.

For a medium voltage grid, it is troublesome to connect only one power semiconductor switch directly. As a result, a multilevel power converter structure has been introduced as different in high power and medium voltage situations. A multilevel converter not only achieve high power ratings, but also enables the use of renewable energy sources. Renewable energy sources such as photovoltaic, wind, and fuel cells can be easily interfaced to a multilevel converter system for a high power application. However, the elementary concept of a multilevel converter to achieve higher power is to use a series of power semiconductor switches with several lower voltage dc sources to perform the power conversion by synthesizing a staircase voltage waveform [4].

Conventional cascaded multilevel inverters are one of the most significant topologies in the family of multilevel and multi-pulse inverters. The cascade topology allows the employ of more than a few levels of DC voltages to synthesize a desired AC voltage. The DC levels are measured to be equal since all of them are fuel cells or photovoltaics, batteries, etc. It requires smallest amount number of components compared to diode-clamped and flying capacitors type multilevel inverters and no particularly designed transformer is required as compared to multi pulse inverter. Since this topology consist of series power conversion cells, the voltage and power level may be easily scaled. The concept of this inverter is based on connecting H-bridge inverters in series to get a sinusoidal voltage output. The output voltage is the sum of the voltage that is generated by each cell. The number of output voltage levels are  $2n+1$ , where n is the number of cells. The switching angles can be chosen in such a way that the total harmonic distortion is minimized. An n level cascaded H bridge multilevel inverter needs  $2(n-1)$  switching [7].

### 3. HYSTERESIS CONTROLLER

The hysteresis voltage control methods have a extremely quick response, easy operation and a variable switching frequency. In conventional fix band hysteresis voltage controller, it is not unworkable to determine hysteresis bandwidth and switching frequency according to system parameters. The hysteresis band (HB) is inversely proportional to the switching frequency of IGBT. In addition, it also determines the quality of the IPFC voltage and consequently the load voltage. In principle rising inverter operation frequency helps to get a improved compensating wave form. However there are device limitations, and growing the switching frequency causes rising switching losses, and audible noise. Hysteresis Voltage Control technique based on bipolar and unipolar PWM is to get better the quality of load voltage [1].

Technique applied in this paper is based on voltage error and is non linear control method. Hysteretic control, also known as bang-bang control or ripple regulator control, maintains the converter output voltage within the hysteretic band, centered about the reference voltage.

The hysteretic-controlled regulator is trendy because of its cheap, easy and easy-to-use architecture. The most profit of hysteretic control are that it offers fast load transient response and eliminates the need for feedback-loop compensation [3]. Until now, research on hysteretic regulators has mostly focused on transient analysis and transient modelling. The hysteresis controller mainly requires two

voltage signals, one is from supply side voltage signal and another is from booster transformer which is voltage injected by IPFC. The controller compares these two signals and according to these signals switching pattern is established. It consists of a comparison between the output voltage and the tolerance limits around the reference voltage, while the output voltage is between upper limit and lower limit. Hysteresis band voltage control is used to control load voltage and determine switching signals for inverter switches. (It terminates the ON-pulse if the ramp voltage exceeds the reference voltage by a certain amount and turns the switch back ON when the ramp falls below a certain threshold a little lower than the reference voltage. It is therefore often called a “bang bang” regulator). If there is a sudden line or load transient, it can react by either turning off totally for several pulses in succession, or by turning ON fully. There are bands above and under the reference voltage. If the difference between the reference and inverter voltage reaches to the upper (lower) limit, the voltage is forced to reduce (increase).

The reference three-phase voltage signals generated is compared by the three-phase IPFC output voltages to generate the switching pluses of the IGBTs independently. The hysteresis band HB is the difference between  $V_H$  and  $V_L$  ( $HB = V_H - V_L$ ). The hysteresis band is inversely proportional to the switching frequency of IGBTs. It also determines the quality of the IPFC voltage and consequently the load voltage. The quality of the IPFC and load voltage is measured using the well-known term Total Harmonic Distortion (THD) [5].

#### 4. IPFC

Interline power flow controller is an extension of the UPFC. This controller employs number of DC to AC converters, provides series compensation. In recent years, power demand has increased gradually, so to control power flows of multiple transmission line we are using interline power flow controllers. IPFC has number of voltage sources inverters which have common DC link, and exchange active power with each other. IPFC equalizes the both real and reactive power flow between the lines and increases the effectiveness of the overall compensating system. Some converters, compensating overloaded lines of reactive power flow can be equipped with full two dimensional, reactive and real power capability. This controller has different applications like compensation of resistive voltage drop through lines and improving the performance of the compensated system when disturbances occur [9].

It is connected between multiple lines and when there is a line overloaded among them this helps in injecting the voltage from those under loaded lines to the over loaded lines through injection transformers, making a balance in transfer of power.

#### 5. RESULTS

The figure 1 represents two transmission line power system with IPFC consisting of sending end and receiving end respectively. The voltage at the sending for the two transmission lines is 33KV which is stepped down to 11KV by the transformers T1, T2. The load connected on the receiving end are rated to 100KVA for both transmission lines. In figure 7 IPFC consists of two VSCs which are connected to the two transmission lines with the aid of series injection transformers. R1, XL1, L1 and R2, XL2 and L2 are the reactance of transmission lines. In order to test the efficiency of control techniques incorporated in IPFC, there are two case studies considered

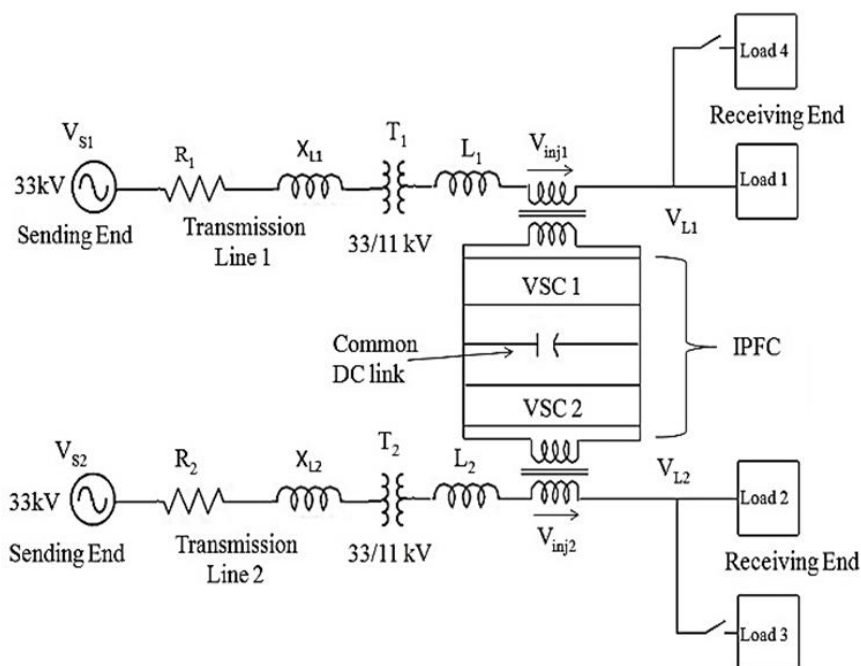
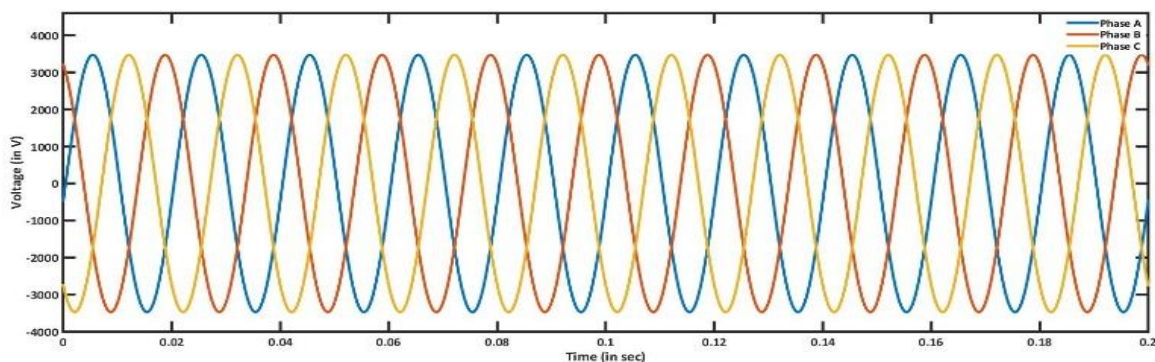

Figure 1. Single line diagram

1. Voltage Drop at the receiving end voltage of transmission line 1.
2. Sudden load on two transmission lines.

In both cases, IPFC is connected to the test system with two control techniques individually. The pulses to the inverter of IPFC is given through these control techniques. Finally a comparative analysis is drawn between the control techniques incorporated in the IPFC. By studying the case studies the best possible control technique for IPFC is investigate

*Voltage Drop at the receiving end voltage of Transmission line 1*



(a)

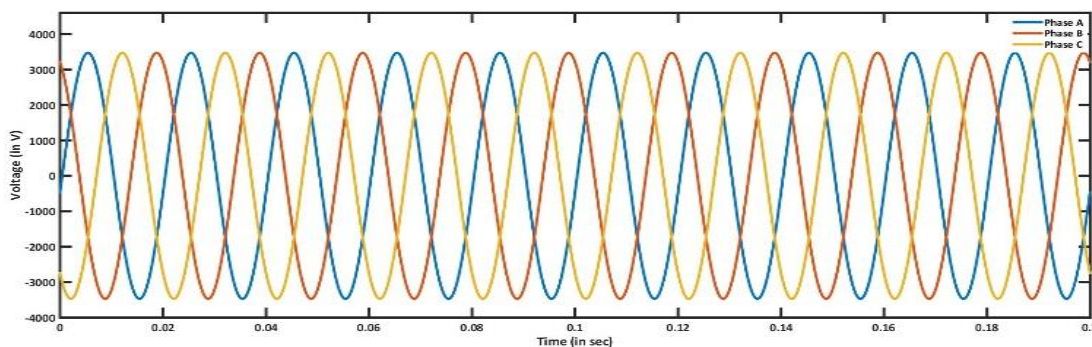

(b)

Fig. 2 a & b, Voltage at the end of transmission line 1 and 2 respectively. In the absence of IPFC.

When the load on the system is increased suddenly at some point then we can see drop in voltage initially and when the load is suddenly increased at 0.1 sec on the system the voltage drastically decreases and there are heavy harmonics seen in the system

### *Sudden Increase in Load on Transmission line 1 and Transmission line 2 simultaneously*

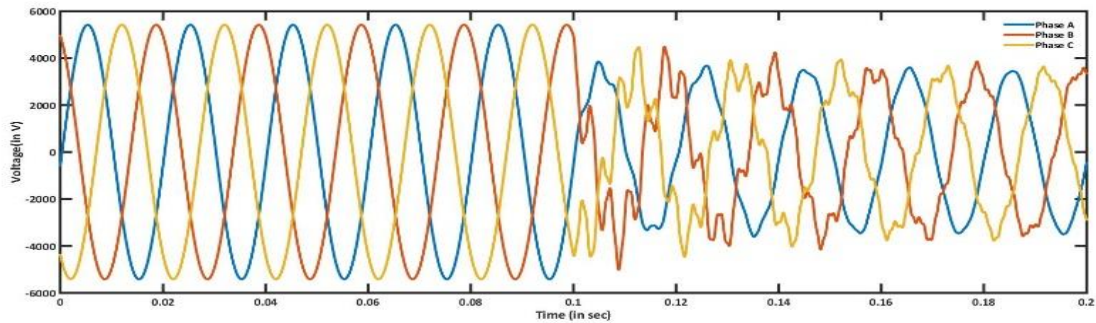

(a)

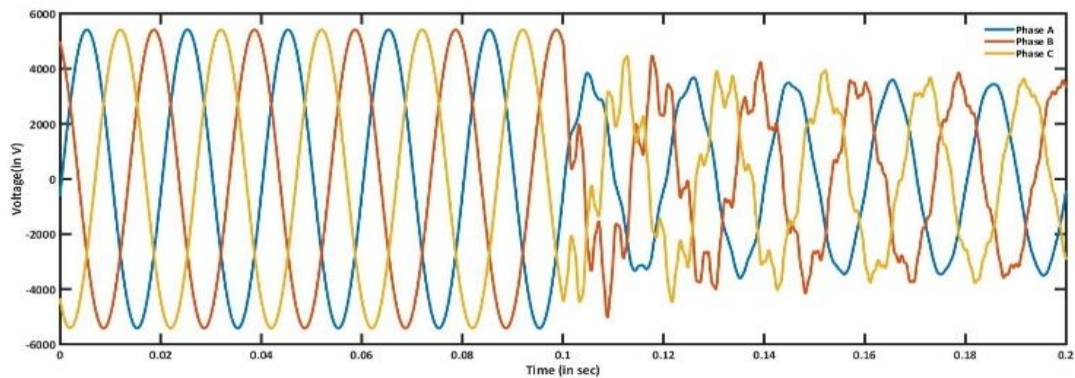

(b)

**Fig. 3** a & b, Voltage at the end of transmission line 1 and 2 respectively. When the load is increased suddenly at 0.1 sec In the absence of IPFC.

### *Sudden Increase in Load on Transmission line 1 and Transmission line 2 simultaneously*

When there is a sudden increase in load at 0.1 sec and now the system is connected with IPFC. In presence of IPFC the system will be able to control the load voltage. Here IPFC is designed with Hysteresis controller. This IPFC makes the system attain 11KV voltage even when there is a sudden increase in load at 0.1 sec, But there are slight harmonics present in the system When the load is suddenly increased

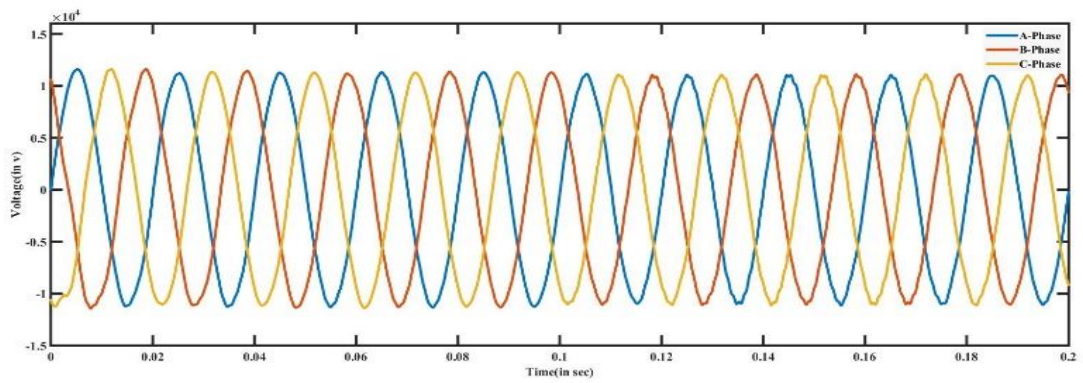

(a)

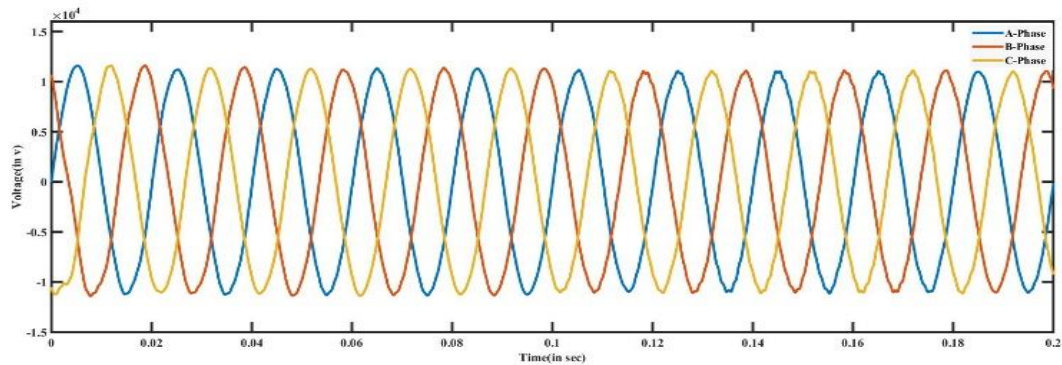

(b)

**Fig. 4** a & b Voltage at the end of transmission line 1 and 2 respectively. When the load is increased suddenly at 0.1 sec In the presence of IPFC-Hysteresis.

From the below figure 10, we can see that the overall THD of the output voltage is 2.55% in the presence of IPFC with Hysteresis controller.

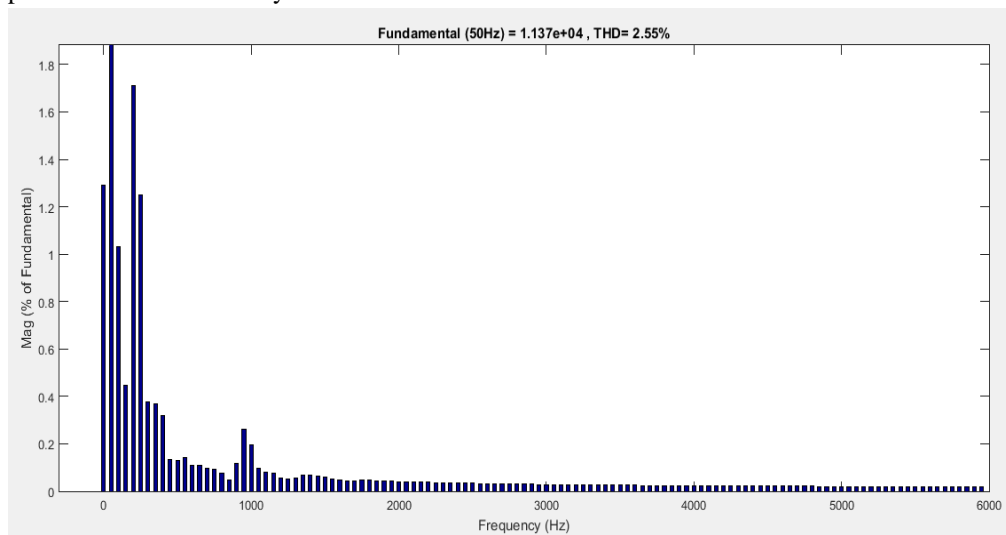

**Fig.5** THD of the system with IPFC-Hysteresis.

When the load is suddenly increased and in presence of IPFC with Hysteresis voltage controller. We can see that the output voltage is very smooth with very few disturbances even when there is a sudden increase in load.

## 6. CONCLUSION

Interline power flow controller is a back to back connection of voltage source converters with a common DC link. This helps in transfer of power among multi line systems, from a under loaded system to a over loaded system. Here IPFC is tested with Hysteresis controller and found that hysteresis controller helps in regulating power with minimum harmonics.

## REFERENCES

1. [https://www.academia.edu/11789578/simulation\\_of\\_the\\_hysteresis\\_voltage\\_control\\_technique\\_in\\_the\\_pv\\_based\\_dynamic\\_voltage\\_restorer\\_for\\_power\\_quality\\_improvement\\_with\\_induction\\_motor\\_drive](https://www.academia.edu/11789578/simulation_of_the_hysteresis_voltage_control_technique_in_the_pv_based_dynamic_voltage_restorer_for_power_quality_improvement_with_induction_motor_drive)
2. [https://strathprints.strath.ac.uk/70297/1/Pena\\_Alzola\\_etal\\_IEEE\\_TOPE\\_2016\\_Control\\_design\\_of\\_a\\_PFC\\_with\\_harmonic\\_mitigation.pdf](https://strathprints.strath.ac.uk/70297/1/Pena_Alzola_etal_IEEE_TOPE_2016_Control_design_of_a_PFC_with_harmonic_mitigation.pdf)
3. [https://www.researchgate.net/figure/Principle-of-hysteresis-Voltage-Control\\_fig4\\_260728992](https://www.researchgate.net/figure/Principle-of-hysteresis-Voltage-Control_fig4_260728992)
4. [https://shodhganga.inflibnet.ac.in/bitstream/10603/9826/6/06\\_chapter%201.pdf](https://shodhganga.inflibnet.ac.in/bitstream/10603/9826/6/06_chapter%201.pdf)
5. <https://www.semanticscholar.org/paper/Power-Quality-Improvement-using-Hysteresis-Voltage-Sivasankari-Shyamala/78551b305736ff2e0f31c9463207ab6a37715415>
6. <https://ieeexplore.ieee.org/document/6533548>
7. <https://pdfs.semanticscholar.org/69a6/31843875924ca8e2e4cc80e273f2e7c3df52.pdf>
8. <https://search.proquest.com/openview/8646facb1bad4e29e74554a4628112d/1?pq-origsite=gscholar&cbl=1686343>
9. <https://www.scribd.com/presentation/128655830/IPFC-Controller>